



**POLICON**  
*Engineering & Manufacturing*

***Machine for  
unscrewing / screwing up  
tubing couplings***

## Description

Machine for unscrewing / screwing couplings, hereinafter referred to as Machine, designed for unscrewing / screwing couplings according to GOST 633-80.

The machine is used in combination with other equipment in technological lines for repairing tubing. The machine can be used independently outside the production lines.

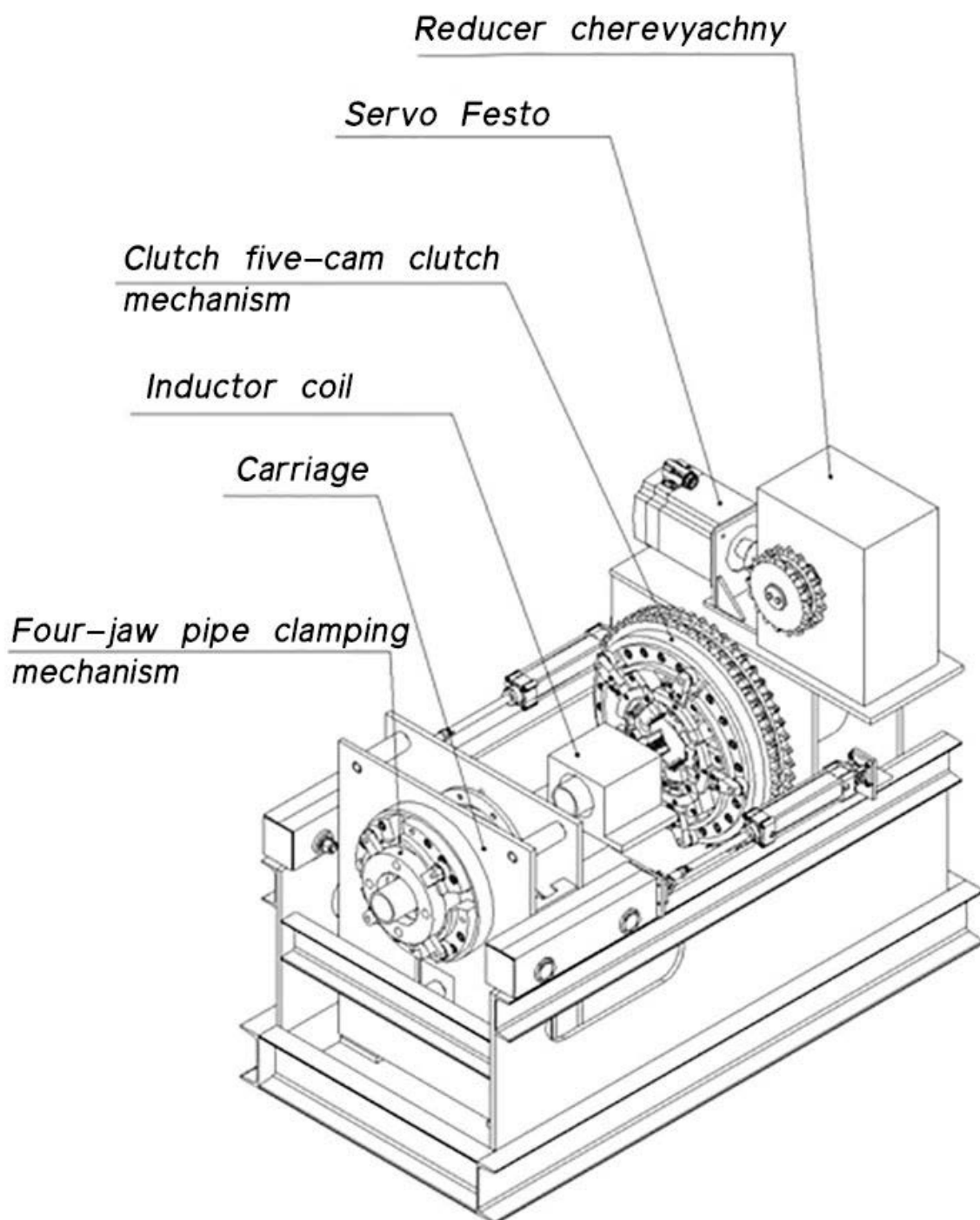

## The composition and description of the machine

Structurally, the Machine consists of the following main components:

- Carriage Machine. Moves along the frame guides with the help of two pneumatic cylinders. On the carriage is a pipe clamping mechanism.

- Pipe clamping mechanism - a cam mechanism with four sliders. In the slider inserted special crackers that are in contact with the pipe during clamping. At the initial stage, the pipe is clamped by a pneumatic cylinder; in the future, the pipe is held by the self-braking mechanism.

- Clutch clamping mechanism - cam mechanism with five sliders. Special rusks are inserted into the slide blocks, which are in contact with the coupling during clamping. At the initial stage, the pipe is clamped by the servomotor while the slide cage is held in place by a special brake (not shown in the diagram), and the pipe is subsequently held due to the mechanism self-braking.

The rotation of the clutch clamping mechanism for the implementation of the lapel of the clutch is carried out by a servomotor through a worm gear motor and an open chain transmission.

- Inductor coil (set by the Customer independently in case of such a need).

- The control system of the machine allows you to work in manual and automatic modes.

## During operation, the Machine performs the following operations with each pipe:

- During operation, the machine performs the following operations with each pipe:
  - supply pipe with a clutch on the roller table to close the main sensor;
  - clamp the pipe in the carriage;
  - heating the coupling in the inductor (if necessary);
  - feeding the pipe with the coupling to the coupling clamp using the carriage drive pneumatic cylinders;
    - coupling clamp;
    - top of the coupling with simultaneous removal of the carriage;
    - after the coupling has separated from the pipe, the coupling is uncoupled and the pipe is pushed into the machine by means of pneumatic cylinders to push the coupling to the removal chute (not shown);
  - unclamping the pipe and removing the pipe from the Machine with the help of a roller conveyor conveyor line.

## Constructive and operational advantages of the machine

- The design of the coupling and pipe clamping mechanisms has proven itself to be more than 10 years of experience in reliable and trouble-free operation.

- The machine is able to develop a torque of up to 12,000 kNm when unscrewing the couplings, which is especially important when unscrewing the couplings from the pipes after long operation.

- The design of the Machine does not provide for the presence of hydro, which reduces the overall cost of maintenance.

- The machine is able to work fully in automatic mode due to the use in the construction of the servo.

## Technical Specifications:

Diameter of pipes for unscrewing / screwing couplings, mm.....	60, 73, 89
Diameters of unscrewed / screw-on couplings, mm.....	73,0; 88,9; 108,0
Type of the drive mechanism of the lapel / frill of the coupling .....	Ectromechanical (servo / gear / open chain)
Type of drive of the coupling clamping mechanism .....	Electromechanical cam
Type of the drive of the mechanism of a clip of a pipe.....	Pneumatic cam
Nominal torque, NxM.....	6000
Power supply, V / Hz.....	380/50
Rated power consumption, kW.....	7,0
Operating pressure in the pneumatic system, atm.....	6,0
Overall dimensions, mm, (without control panel and pneumatics shkaf):	
length.....	2 200
width.....	1 500
height.....	1 400
Machine axis height.....	850
Machine weight, kg.....	2 400
Management (1 operator) .....	Manual / Auto

This product can be manufactured according to the customer's specifications, taking into account its specified parameters and features.

## **Food Machinery**

**Machinery for tires, rubber, plastics manufacturing**

**Modernization and automation of production**

**Non-standart equipment**

**Production of spare parts, components, assemblies**

**Outsourcing services - repair and maintenance  
of equipment**

**Global engineering solutions**

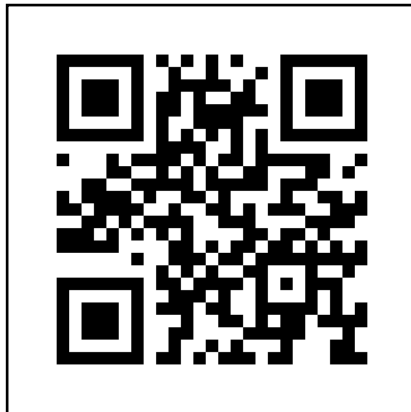

**Policon JSCo**

**194 Lermontov Str, Omsk 644009, Russia**

**Tel./Fax: +7 (3812) 36 74 12, 36 74 02, 48 48 30**

**e-mail: [info@policon-rt.ru](mailto:info@policon-rt.ru)**

**[www.policon-rt.ru](http://www.policon-rt.ru)**